

# Waste Water Treatment Units

RBBR Rotating Bed Biofilm Reactor  
Patented waste water treatment

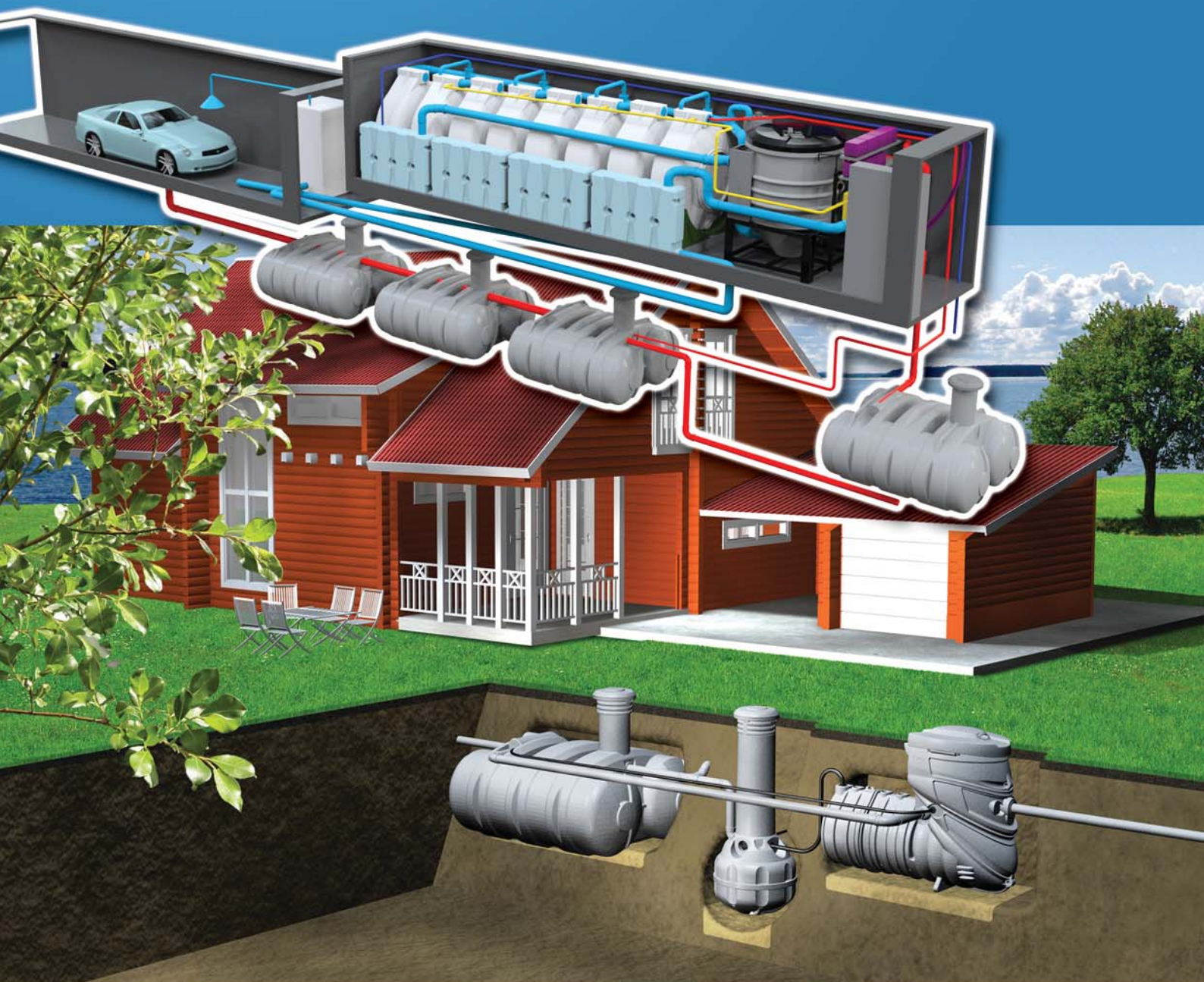

**CLEWER**<sup>®</sup>  
c l e a n w a t e r

# Clewer Process

**F**ast recovery, couple of days, after a long shut-down period.

**C**an accept very low and very high loads.

**V**ery long emptying interval for sludge tank.

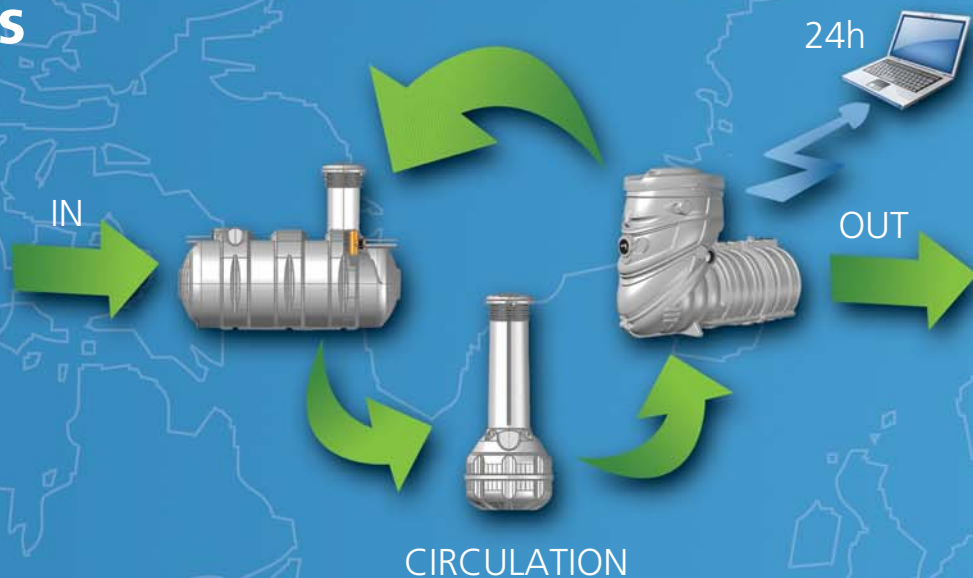

# Clewer Technology

## Patented RBBR Rotating Bed Biofilm Reactor

- Very high filling ratio 85% with carriers for maximum quantity of bacteria.
- Self-cleaning reactor because of rotation.
- Air for bacteria generates the rotation in economic and easy way.
- Bacteria can use air efficiently, because they rotate together long time.



## Patented Cycloop Optical Sensor

- Cycloop follows water quality by measuring turbidity of the cleaned water.
- User can see daily reports, water quantities and alarms of his own unit in Internet.

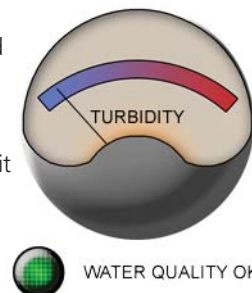

## Patented CLEWER Start-up Enzyme

- Gives immediate start-up after installation of the Clewer unit.
- Is highly trained and resistant against typical solvents used in home.



## Flotation Unit

- Flotation unit removes small particles by using micro bubbles. Micro bubbles bring small particles and grease on top of the surface and they are then removed mechanically to sludge tank. Clewer flotation uses patented Wiser technology.



**C**lewer Units are **CE-tested** with full load and they achieve **excellent reduction rates**. For all Clewer Units we give cleaning result guarantee – we keep our promises.

**C**lewer units are tested with unique stop-test: From full load unit was shut-down totally for 3 months, even electricity was cut-off. After restart with full load **the process started immediately** and achieved required reduction rates in couple of days.

**C**lewer Units are **easy to use**, as they do not require any special activities from the user.

# Clewer waste water treatment units, selection table and technical table

Capacity	800S	1300S	2000S	6M	12M
High nitrogen reduction (more than 50%), Equivalent persons max. (1)	5	15	79	50	150
Low nitrogen reduction (less than 50%), Equivalent persons max. (1)	12	36	188	120	320
Waste water flow (Nitrogen reduction more than 50%) max, m <sup>3</sup> /day (2)	1.2	3.6	18.8	12.0	32.0
Waste water flow (Nitrogen reduction less than 50%) max, m <sup>3</sup> /day (3)	2.0	6.0	31.4	20.0	53.3
BOD reduction, % (4)	95	95	95	95	95
Phosphorus reduction, % (5)	90	90	90	90	90
Car wash unit, max flow m <sup>3</sup> /h	-	-	-	5,6	15
Car wash unit, max. capacity cars / day (6)	-	-	-	169	450
Reactor RBBR volume, m <sup>3</sup>	0.60	1.80	9.42	6.00	16.00

## Sludge tank and pump well

Sludge tank, volume in liters	S-5000	S-15000	S-30000	S-30000	2 X S-30000
Pump well (7)	P-450	P-450	P-5000	P-5000	P-5000

## Electricity

Electricity consumption in full operation, kW (8)	0.1	0.3	1.6	1.0	2.7
Electricity consumption estimation, kWh/year	876	2628	13753,2	8760	23360
Fuse size, A	1 x 10A	1 x 10A	1 x 10A	3 x 25 A	3 x 25 A
Voltage	230 V, 50 Hz	230 V, 50 Hz	230 V, 50 Hz	400 V, 50 Hz	400 V, 50 Hz

## Dimensions and weights

Reactor dimensions D, L, H or L, W, H, mm	D 800, L 2380, H 1846	D 1300, L 3290, H 2080	D 2000, L 6000, H 2500	L 6050, W 2440, H 2900	L 12192, W 2440, H 2900
Connection pipe diameter in/out, mm (9)	110/110 (or /40)	110/110 (or /40)	160/160 (or /63)	160/160 (or /63)	160/160 (or /63)
Chemical tank size, l	75	150	300	200 Pipeline Smart	200 Pipeline Smart
Reactor weight dry, kg	100	200	1000	4600	8000
Reactor installed under/on ground	Underground	Underground	Underground	On ground, in 20' container	On ground, in 40' container

## Chemicals

Chemical consumption per waste water flow, ml/m <sup>3</sup> (10)	180	180	180	180	180
Chemical type for Phosphorus removal from waste water (11)	Clewer PAC	Clewer PAC	Clewer PAC	Clewer PAC	Clewer PAC
Chemical consumption in car wash unit, ml/car	-	-	-	25	25
Chemical type in car wash unit	-	-	-	Clewer Nutrient CL20	Clewer Nutrient CL20

## NOTES:

- |   |  |
|---|--|
| 1) Minimum is 1 (0) persons   | 7) Number is buffer volume in liters   |
| 2) Outlet suspended solids max. 15 g/l, if flow 50 % then max. 5 mg/l | 8) Peak power consumption is double  |
| 3) Outlet suspended solids max. 30 mg/l                               | 9) /40 or /63: Outlet with pressure pipe, max. 100 m distance and 5 m height |
| 4) If lower reduction, then capacity increases!                       | 10) For Phosphorus removal   |
| 5) Adjustable with amount of chemical                                 | 11) PAC is not needed in car wash unit                                       |
| 6) With Pipeline washing chemicals                                    |  |

Water temperature: Above capacities are acc. to cold climate area. If water is warmer than +18 °C, above capacities can be multiplied with factor 1.5.

Max. water temp. is +30...35 °C. For very cold conditions, arctic climate, units can be equipped with electric heating in critical components (especially if in intermittent use).

Above capacities m<sup>3</sup>/d and equivalent persons are acc. to CE test and with regulations in Finland (In Finland BOD 50 g/p/d, Nitrogen 14 g/p/d and Phosphorus 2.2 g/p/d).

Two units can be installed parallel for higher capacity. If using common sludge tank, requires one extra pump.

# Clewer Units

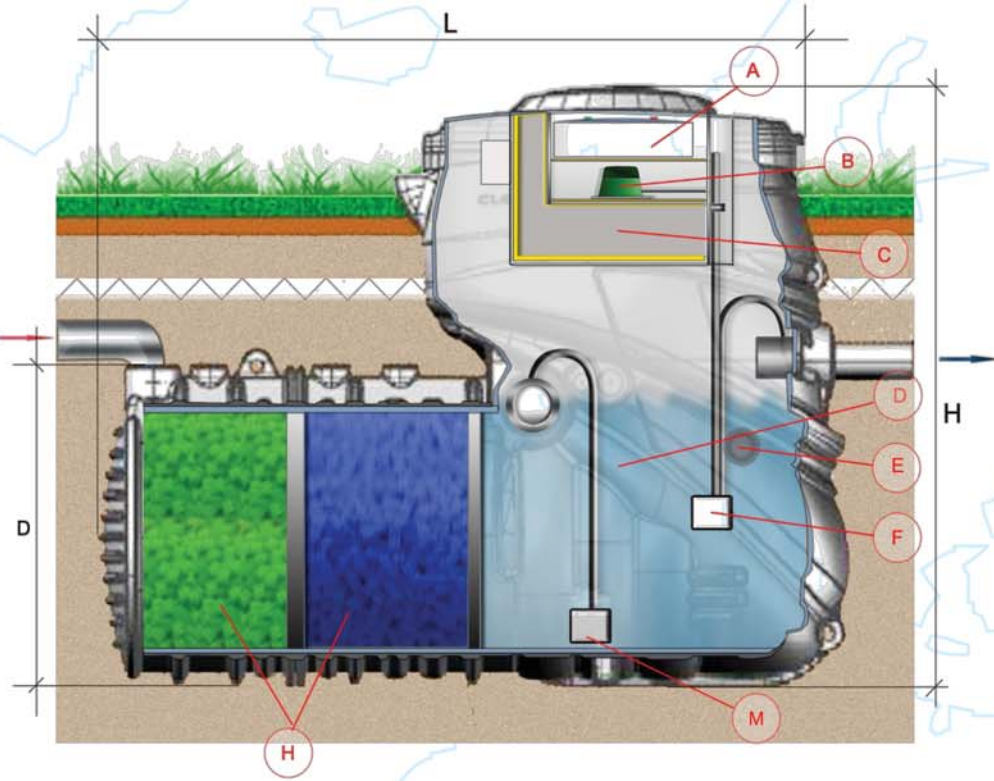

UNDERGROUND MODEL 800S/1300S FOR SINGLE/MULTIPLE HOUSE WASTE WATER TREATMENT

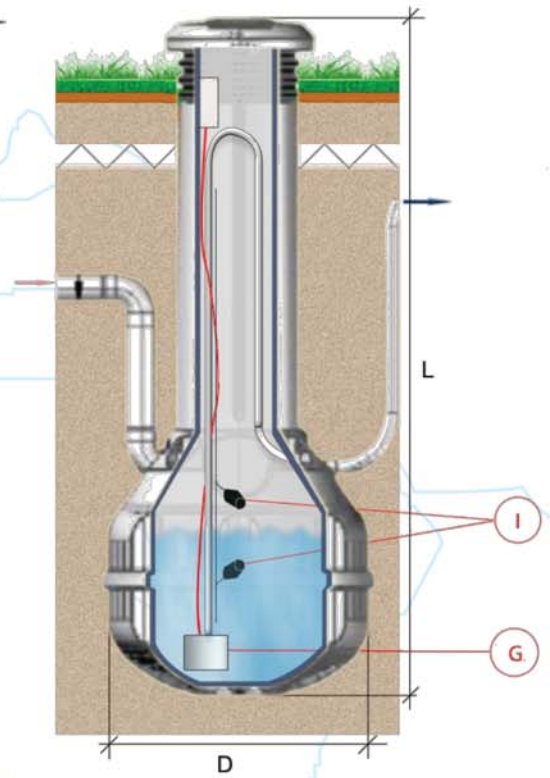

PUMP WELL P-450

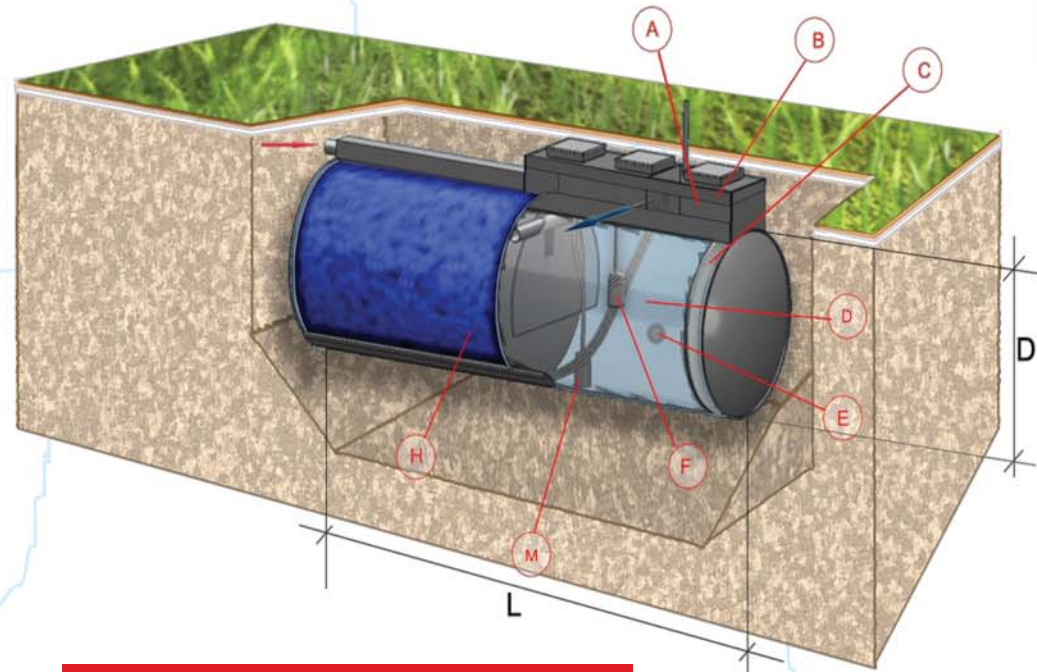

UNDERGROUND MODEL 2000S FOR MUNICIPAL WASTE WATER TREATMENT

ON GROUND CONTAINER MODEL 6M/12M FOR MUNICIPAL WASTE WATER TREATMENT

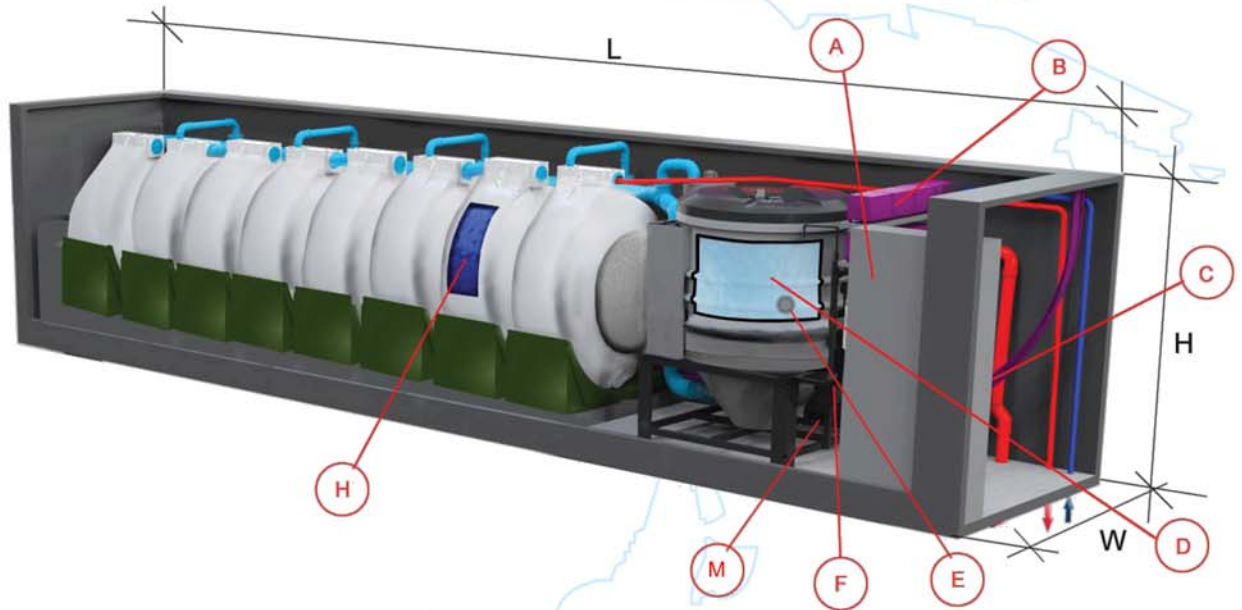

ON GROUND CONTAINER MODEL 6M/12 M FOR CAR WASH WATER TREATMENT AND RECYCLING

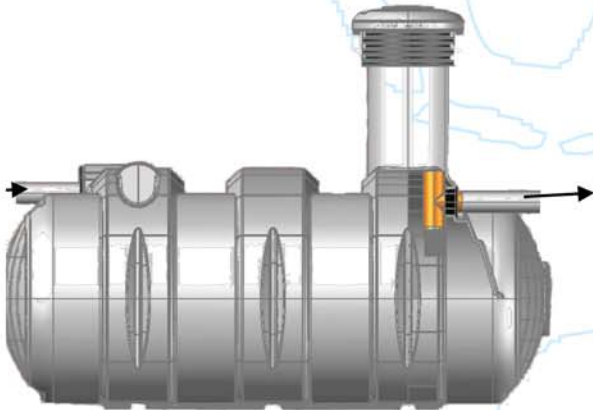
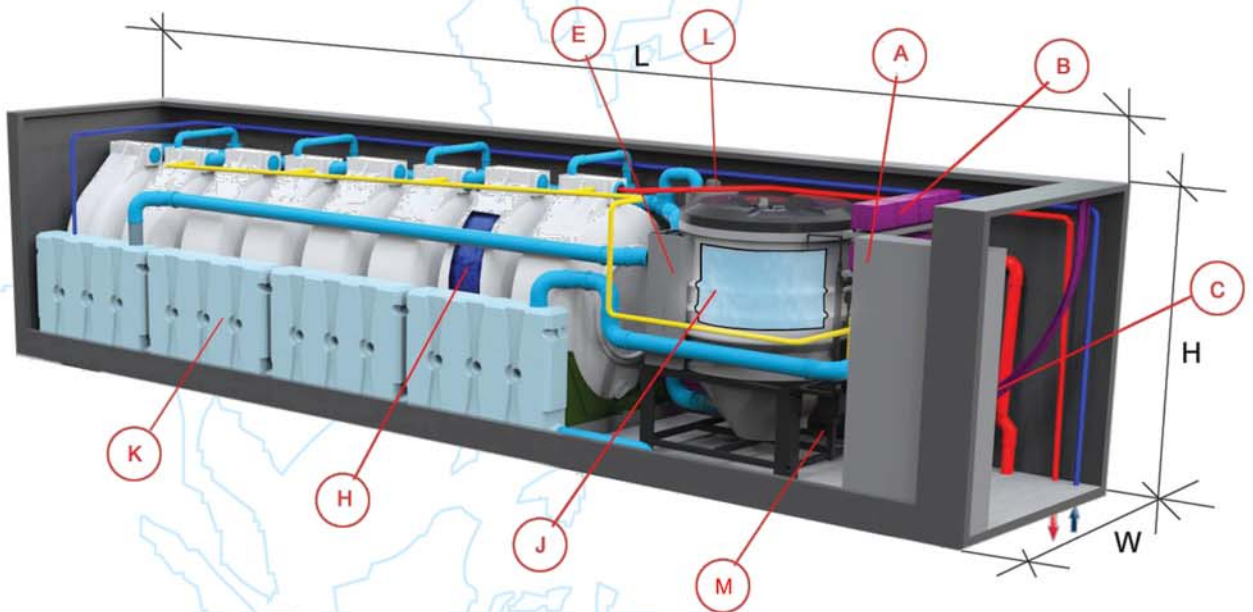

SLUDGE TANK S-5000

- A - CONTROL BOX
- B - AIR PUMPS
- C - CHEMICAL TANK & PUMP
- D - CLARIFIER
- E - OPTICAL SENSOR
- F - OUTFLOW PUMP
- G - CIRCULATION PUMP
- H - ROTATING BED BIOFILM REACTOR
- I - WATER LEVEL SENSORS
- J - FLOTATION UNIT
- K - CLEAN WATER TANKS
- L - FOAM KILLER

# Clewer Applications

Single houses waste water treatment

Two or three houses waste water treatment

Village waste water treatment

Car wash water treatment and recycling

Fish farming water treatment and recycling

Laundry water treatment and recycling

Dairyfarms milky and flush water treatment

Food industry waste water treatment

Tailor made solutions

Clewer is an environmental technology company with products that are specialized in innovative waste water treatment systems.

Clewer has developed and patented centrifugal bioreactor for waste water treatment, the RBBR technology. Clewer is growing very fast and products are sold worldwide. Clewer is part of Salmela group and head office is located in Turku, Finland.

[www.clewer.com](http://www.clewer.com)



**CLEWER**<sup>®</sup>  
c l e a n w a t e r

Leverage from  
the EU  
2007-2013



European Union  
European Regional Development Fund